

GAZ-SYSTEM FORUM

2024

**New source of gas supply
to Poland - FSRU Program
status**



FSRU PROGRAM - SIGNIFICANCE:

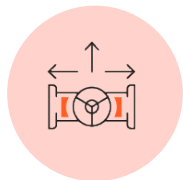

Third element of the Northern Gateway

(beside Świnoujście LNG Terminal and Baltic Pipe pipeline) - infrastructure projects aimed at diversifying gas supplies to Poland and the region.



The project is in line with the strategic assumptions and objectives of the Polish energy policy

The project fully corresponds with diversification plans of natural gas supply sources and routes of natural gas supply and to guarantee Poland's energy security.



The project fully complies with the objectives of the EU energy agenda

The FSRU program was included by the European Commission in the PCI list and was granted the status of a project of common interest in the energy sector.

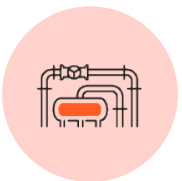

Component of the EU's critical gas infrastructure (identified in the REPowerEU plan) which will contribute to a rapid reduction of the dependence of countries in the region on Russian fossil fuels and accelerating the energy transition.



Currently, the FSRU Program is designed to provide 6.1 bcm regasification capacity (FSRU-1).

PROJECT COMPONENTS IN FSRU PROGRAM

Business + VESSEL Project (GAZ-SYSTEM):

- **FSRU-1 vessel** designated as a pivotal element of the entire plant providing storage and regasification capacity will also become a new source of supply and entry point to the NTS.

Offshore Project - Offshore part of the FSRU Terminal (GAZ-SYSTEM):

- **Mooring and berthing jetty** with all the necessary equipment and process installations.
- **Offshore gas pipeline of approx. 3.3 km** connecting the jetty with the Onshore Project.

Onshore Project - NTS (GAZ-SYSTEM):

- **Extension of the NTS with three gas pipelines** to enable efficient distribution of gas from the Gdańsk area to customers in Poland and in the region:
 - Kolnik – Gdańsk gas pipeline (DN1000, ~34 km),
 - Gustorzyn – Wicko gas pipeline, section Gardeja – Kolnik (DN1000, ~88 km),
 - Gustorzyn – Wicko gas pipeline, section Gustorzyn – Gardeja (DN1000, ~128 km).

Construction of a new breakwater (Maritime Office in Gdynia):

- Together with the FSRU Terminal, approx. ~ 1.3 km long breakwater will be constructed in the Port of Gdańsk.
- The entity in charge of the implementation of this project component is the **Maritime Office in Gdynia**; preparatory work and design engineering are underway

GAZ-SYSTEM FORUM

2024

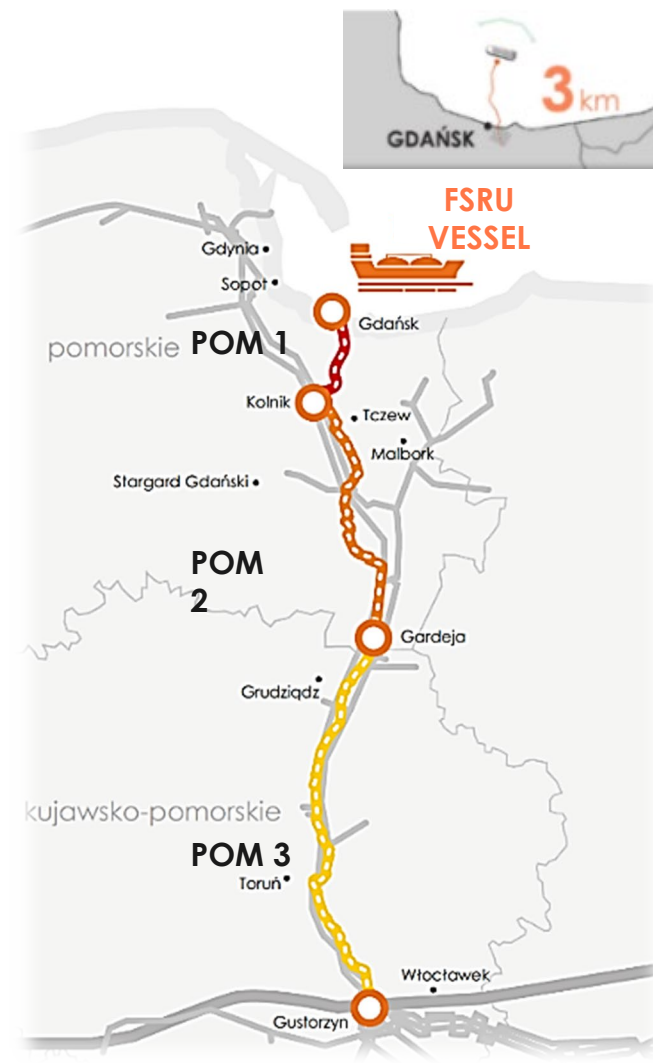

KEY DEVELOPMENTS OVER THE PAST 6 MONTHS

GAZ-SYSTEM FORUM

2024

FSRU TIME CHARTER PARTY SIGNED

– TCP was signed with White Eagle Energy Ltd. (SPV M.O.L.) on 19.04.2024.

OFFSHORE PERMITTING PROCESS

– Decision on environmental conditions was obtained in February, location decision and water permit for the Offshore part were obtained in July 2024. The application for Construction Permit was submitted in September.

OFFSHORE EPC CONTRACT AWARD PROCEDURE

- Corporate approvals were obtained in May 2024 and followed by proceedings for the implementation phase were launched under the EPC formula. The signing of the contract with the selected EPC contractor is expected in the first quarter of 2025.

CONTRACTS FOR THE ONSHORE PART SIGNED

– All contracts for investor delivered items (pipes, fittings, induction bends) were finalised in July 2024.

FINAL INVESTMENT DECISION

- Orlen S.A. was notified of the Final Investment Decision on 12.08.2024.

CONTRACT AWARD FOR CONTRACTOR OF CONSTRUCTION WORKS AND INVESTOR SUPERVISION ON THE ONSHORE PART

– Three proceedings for Contractor of Construction Works and two proceedings for Investor Supervision were launched in April 2024.

Investor Supervision contracts for all onshore projects are concluded.

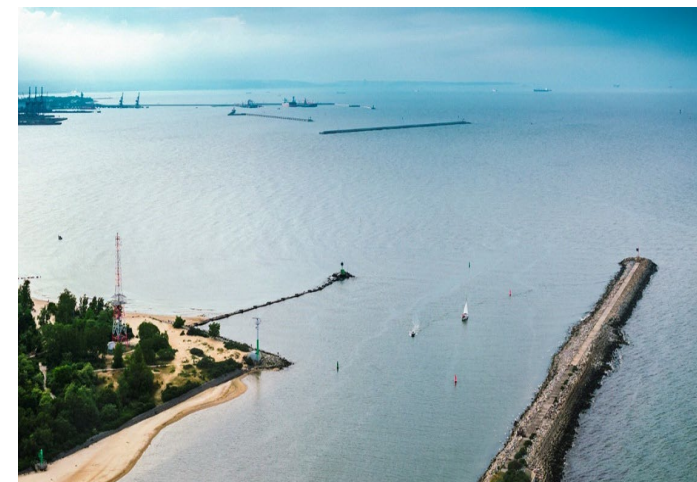

FSRU PROGRAM FRAMEWORK SCHEDULE



2024

- Conclusion of TCP for the vessel
- Commencement of contract award procedures for Contractor of Construction Works, Investor Supervision and investor provided items in Onshore component
- Launch of contract award procedure for EPC Offshore
- Commencement of FSRU design engineering
- Signing of contracts with Investor Supervision and Contractor of Construction Works Onshore
- Obtaining the Construction Permit for the Offshore part



2025

- Signing of EPC Offshore contract
- Completion of deliveries of investor provided items for the Onshore part
- Commencement of construction works on the Onshore part
- Completion of design engineering and launching the FSRU construction phase at a shipyard
- Mobilisation of EPC Contractor for the Offshore part, commencement of dredging works



2026

- Approval of detailed engineering designs for the Offshore part.
- Construction works on the Offshore part are continued.
- **Completion of construction work and acceptance tests in the Onshore part**



2027/2028

- **Completion of vessel construction, testing and transport of the vessel to Gdańsk**
- Offshore part commissioning
- Tariffs, licensing and regulatory approvals
- **Start of FSRU operations**

WORK PROGRESS STATUS

BUSINESS + VESSEL PROJECT

COMPLETED/IN PROGRESS:

▶ TIME CHARTER PARTY:

- Detailed arrangements of the outstanding annexes to the FSRU time charter party signed in April 2024 are in progress.

▶ FSRU Design Engineering/Plan Approval Phase (verification of FSRU vessel design documentation):

- Design engineering work commenced at the HHI shipyard in Ulsan (kick-off HHI/MOL/GS).
- Commencement of the official process of reviewing the design documents for the FSRU is planned.

▶ Selection of a General Technical Advisor: RFI procedure was completed.

- RFI procedure was conducted.
- Preparation for the RFP procedure is underway.

PLANNED WORK:

- ▶ Commencement of the review of FSRU design documentation
- ▶ Selection of a General Technical Advisor



WORK PROGRESS STATUS

OFFSHORE PROJECT

COMPLETED/IN PROGRESS:

► Design engineering:

- FEED documentation approved in June 2024.
- Construction design (land development plan, building design)- submitted to Regional Office.
- Seabed surveys including UXO, CHO, geological campaigns were conducted

► Administrative decisions

- Regional Directorate for Environmental Protection in Gdańsk issued the environmental decision in February 2024.
- In July 2024, the Pomeranian Regional Office issued the investment location decision.
- In July 2024, a Branch office of Wody Polskie in Gdańsk issued a water permit.
- Application for construction permit submitted to Pomeranian Regional Office.

► EPC contract award procedure:

- In May 2024, corporate approvals were obtained and contract award procedure for EPC was launched.
- A 'shortlist' of potential EPC contractors was approved in August 2024, and it will be followed by an invitation to tender with updated documents (Draft contract, Contract Specification, construction design and FEED).

► Contract Engineer selection procedure:

- The RFI procedure was completed in August 2024.
- Procedure to be launched in October 2024

PLANNED WORK:

- Construction Permit to be obtained
- Contract with the EPC and Contract Engineer to be signed

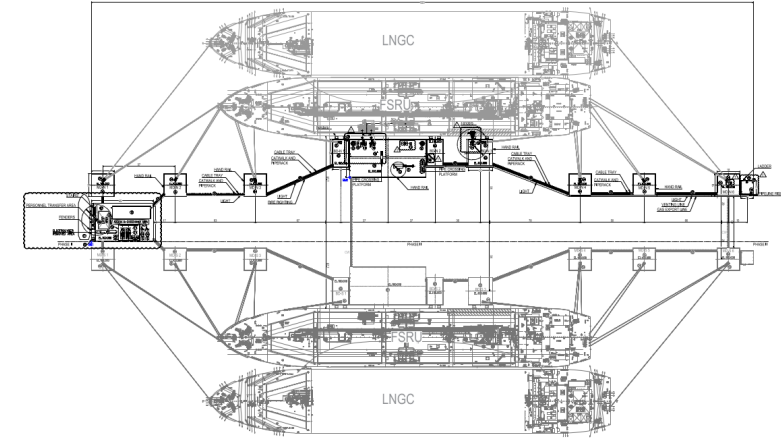

WORK PROGRESS STATUS

ONSHORE PROJECT | POM 1, POM 2, POM3

COMPLETED/IN PROGRESS:

► Selection procedure for Construction Work Contractor:

- **POM1:** The award of the contract was announced on 06.09.2024.
- **POM2:** On 08.07.2024 the bid opening took place. Clarifications concerning the lowest bid and abnormally low price are in progress. The announcement of the contract award is planned in early October 2024.
- **POM3:** On 04.07.2024 the bid opening took place. Clarifications with bidders regarding the abnormally low price are ongoing. The announcement of the contract award is planned in early October 2024.

► Selection procedure for Investor Supervision:

- **POM1:** Contract with ECM Group Polska S.A. concluded on 06.09.2024.
- **POM2 and POM3 (Joint Proceedings):** Contract with MGGP S.A. was concluded on 30.08.2024

► Investor Provided Items:

- Supply contracts for all onshore projects have been signed.

PLANNED WORK

- Signing contracts awarded to all Construction Work Contractors in Onshore projects





GAZ-SYSTEM FORUM

2024

Maciej Wawrzkowicz
FSRU OFFSHORE Project Manager